

AUGC10DH THRU AUGC10MH
● FEATURES

- * Halogen-free type
- * Compliance to RoHS product
- * GPRC (Glass passivated rectifier chip) inside
- * Glass passivated cavity-free junction
- * Lead less chip form, no lead damage
- * Low profile package
- * For surface mounted applications
- * Plastic package has Underwriters Laboratory Flammability Classification 94V-0
- * Comply with AEC-Q101

● APPLICATION

- * General purpose rectification
- * Surge absorption
- * Automotive

● MECHANICAL DATA

Case : Packed with FRP substrate and epoxy underfilled

Terminals : Pure Tin plated (Lead-Free), solderable per MIL-STD-750, Method 2026.

Polarity : Cathode Band, Laser marking

Weight : 0.02 gram

● PACKING

- * 3,000 pieces per 7" (178mm ± 2mm) reel
- * 4 reels per box
- * 6 boxes per carton

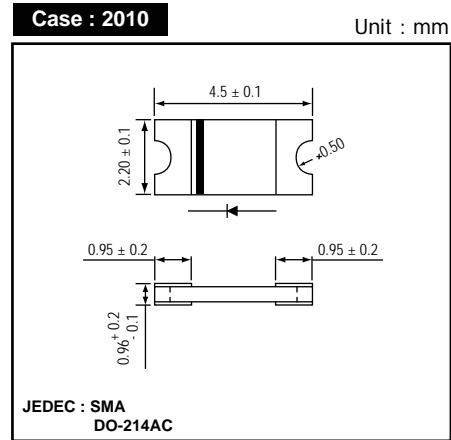
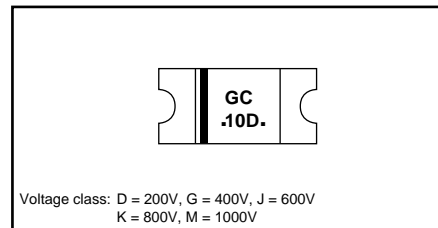
● OUTLINE DIMENSIONS

● MARKING

Absolute Maximum Ratings (Ta = 25 °C)

ITEM	Symbol	Rating					Unit
		AUGC10DH	AUGC10GH	AUGC10JH	AUGC10KH	AUGC10MH	
Repetitive peak reverse voltage	VRRM	200	400	600	800	1000	V
Average forward current	IF(AV)	1.0					A
Peak forward surge current (8.3ms single half sine-wave)	IFSM	30					
Operating junction temperature Range	Tj	-65 to +175					°C
Storage temperature Range	TSTG	-65 to +175					

Electrical characteristics (Ta = 25 °C)

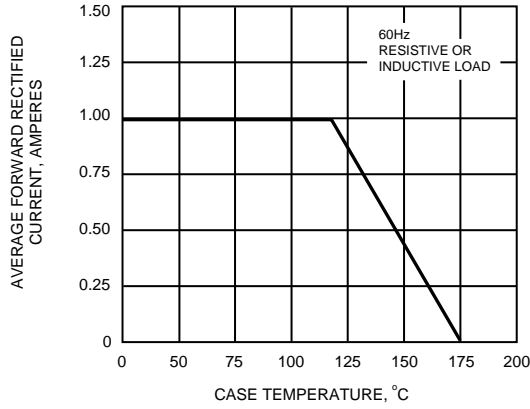
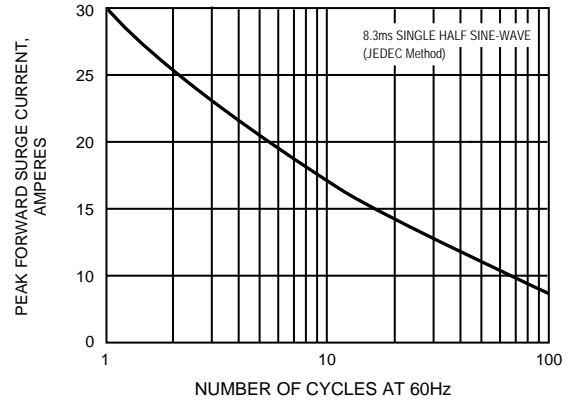
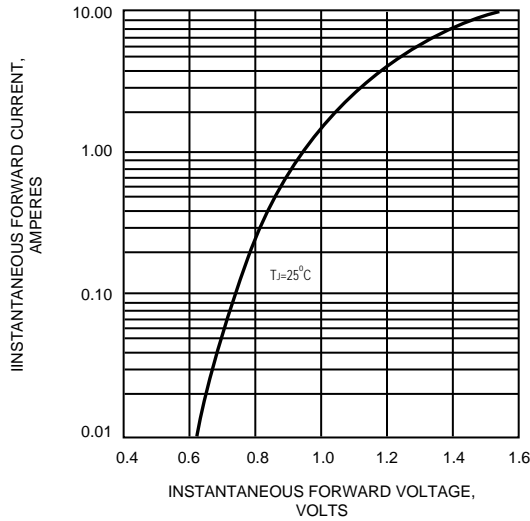
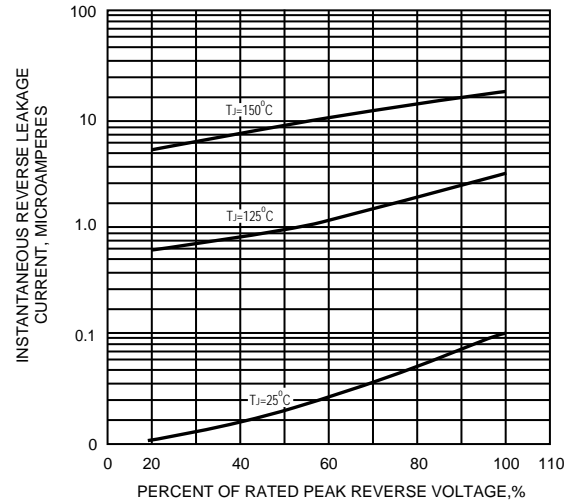
ITEM	Symbol	Conditions	Min.	Typ.	Max.	Unit
Forward voltage	VF	IF = 1.0A	-	0.94	1.00	V
Repetitive peak reverse current	IRRM	VR = Max. VRRM , Ta = 25 °C	-	0.10	5	uA
Junction capacitance	Cj	VR = 4V, f = 1.0 MHz	-	8	-	pF
Thermal resistance	Rth(JA)	Junction to ambient (NOTE)	-	115	-	°C/W
	Rth(JC)	Junction to lead (NOTE)	-	21	-	

NOTES : Thermal resistance from junction to ambient and from junction to lead P.C.B. mounted on 0.2 x 0.2" (5.0 x 5.0mm) copper pad areas.

FIG.1 - FORWARD CURRENT DERATING CURVE

FIG.2 - MAXIMUM NON-REPETITIVE PEAK FORWARD SURGE CURRENT

FIG.3 - TYPICAL INSTANTANEOUS FORWARD CHARACTERISTICS

FIG.4 - TYPICAL REVERSE CHARACTERISTICS

FIG.5 - TYPICAL JUNCTION CAPACITANCE
